

APPLICATION	AXLE	SCALE	REV.	DATE	SHIM 033
	R	100%	00	23/10/2017	
BENTLEY: FLYNG SPUR 03.13 - BUICK: LA CROSSE, LA CROSSE II, REGAL V (USA) CADILLAC: XTS (USA) 09.11- CHEVROLET: IMPALA, MALIBU VII, MALIBU VIII OPEL: INSIGNA (G09) SAAB: 9-5 II VAUXHALL: INSIGNA	W.V.A. 24421 24422	FMSI D-1430 8547	O.E.	 MORETTO BRAKE PADS COMPONENT	

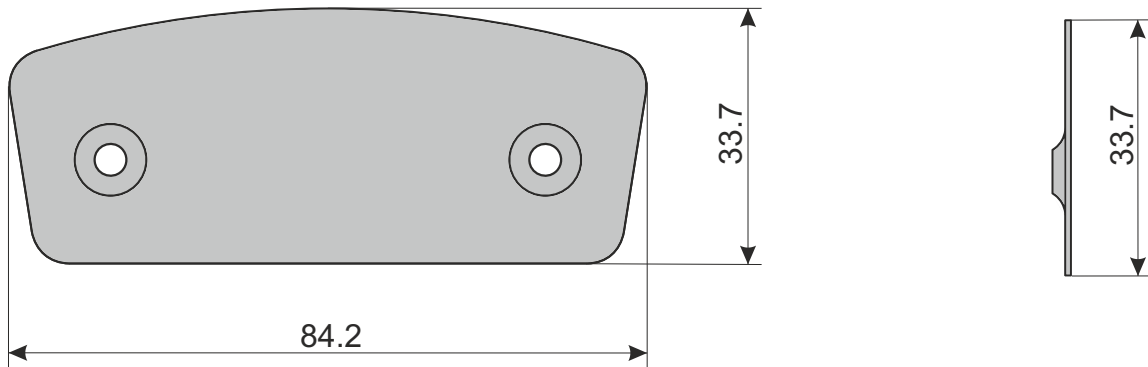

Drawing in CAD corrections are not allowed
TOLLERANCE± 0.5